

Series
200

Super Pro

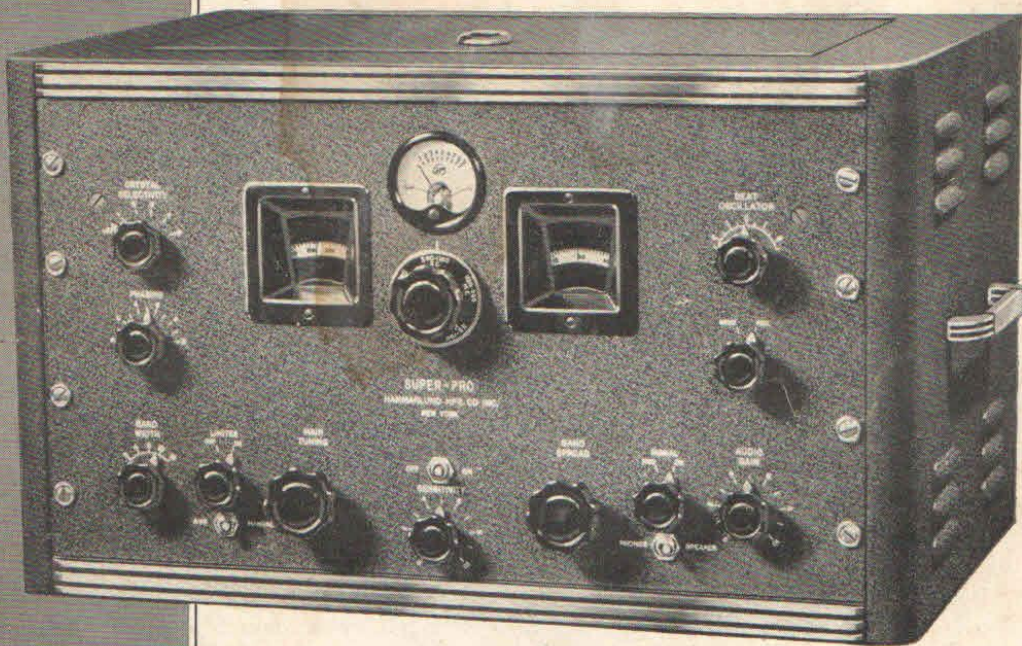

HAMMARLUND

SERIES 200 SUPER-PRO

BY

HAMMARLUND



THE HAMMARLUND Series 200 "Super-Pro" is an 18-tube professional type receiver embodying the latest developments in the communication field. Flexibility was the main objective during the many years of research and engineering required to develop this outstanding receiver. The "Super-Pro" is not limited as to performance. In its design are incorporated features which permit the receiver to be used for practically every type of service known to the art. In many installations, it will be found that the "Super-Pro" will take the place of several special receivers which are usually necessary where the service is diversified. The Series 200 "Super-Pro" is designed mechanically and electrically for continuous duty and, therefore, is ideal for commercial, military, or civilian services where exceptional performance under strenuous conditions is demanded.

There are three major requirements to be considered in the design of a high frequency receiver. They are, sensitivity, selectivity, and stability. The sensitivity of any receiver is limited by the noise generated in the first tuned circuit and also the grid noise of the first tube. By providing a large step-up of signal voltage between the antenna and the first tuned circuit, and also obtaining considerable amplification in the first stage, a very favorable signal-to-noise ratio has been obtained on fractional microvolt signals with the "Super-Pro."

Selectivity depends upon the band width of the I.F. amplifier and is usually a compromise between fair audio quality and sharp tuning. In the "Super-Pro," there is no compromise. The band width is variable over a range of from 16 kc. to better than 100 cycles. This permits perfect quality reproduction where interference allows the use of a wide channel and in any case the operator can adjust the selectivity for best quality with a minimum of interference. The stability of the "Super-Pro" is extremely good. Only the best of materials and workmanship are built into this receiver and the result is a design which has been widely accepted by leading communications engineers. The "SP-200" has been thoroughly engineered from every possible angle. Every feature that will contribute to the performance of a communications receiver has been built into the "SP-200." No compromises have been made in order to hold down production cost. Every effort has been made to produce the finest receiver that money can buy. Complete mechanical and electrical details are included in the following pages.

MECHANICAL DETAILS: Mechanically the "SP-200" is the last word in radio receiving apparatus. Every part is designed for maximum mechanical durability as well as electrical efficiency. The mechanical safety factor of every part is many times that required even under the severest operating conditions. The entire receiver, not including the power supply, is built on a heavy re-inforced steel chassis 17 x 14 $\frac{1}{4}$ x 3 $\frac{1}{2}$ inches. The panel is 3/16" aluminum and measures 19 x 10-15/32 inches.

The tuning assembly of the "SP-200" is a self-contained unit. This assembly contains the four main tuning condensers, 12 band spread condensers, 20 tuning coils mounted on Isolantite bases with their associated padders and trimmers and special cam-operated knife switch for changing bands. The tuning dials are driven by friction

and operate smoothly and accurately. The main dial is so designed that when the wave band switch is rotated, the proper calibrated dial scale appears behind the window. The variable selectivity control mechanically varies the coupling between the primary and secondary of the I.F. transformers. This requires a special cam device as well as special mechanical arrangement of the I.F. transformers that are controlled in this manner. Refer to drawing for complete details. The power supply for the "SP-200" is a special heavy duty unit. This unit is completely shielded and it is also available for rack mounting. Mounting the power supply on a separate chassis in this manner greatly reduces the temperature rise and, of course, improves overall stability of the receiver.

TUBE LINE-UP

6K7 — First tuned R.F.	6N7 — Noise limiter
6K7 — Second tuned R.F.	6SK7 — AVC driver
6L7 — Mixer	6H6 — AVC Diode
6J7 — H.F. Oscillator	6SJ7 — B.F. Oscillator
6K7 — First I.F. Amplifier	6C5 — First A.F. Amplifier
6SK7 — Second I.F. Amplifier	6F6 — Second A.F. Amplifier
6SK7 — Third I.F. Amplifier	2-6F6 — Third A.F. Amplifier (Push-Pull)
6H6 — Second Detector	5Z3 — High Voltage Rectifier
	80 — C-Bias Rectifier

DESIGN

The general design of the new "Super-Pro" embraces over five years of extensive research and experimentation. Individual components in the majority of cases have been specially designed for this receiver. The tuning inductors contained in the tuning unit are individually wound on low-loss forms. There are 20 in this group. Each coil has its own form and is mounted on an Isolantite base. This base also accommodates the variable trimming capacitor. All oscillator trimmers are of the air dielectric type and add considerably to the overall stability of the receiver. High stability mica trimmers are employed in the R.F. circuits.

The band change switch is especially designed for the "Super-Pro" and is unlike any other switch used for this purpose. The cam-operated knives contact stationary fingers and complete the circuit. Thus, no moving part carries current to cause noise or stray coupling. All contacts are silver-plated and will provide years of reliable

FIG. 1—Band width control which varies selectivity and permits the operator to adjust the receiver for best quality obtainable with minimum interference.

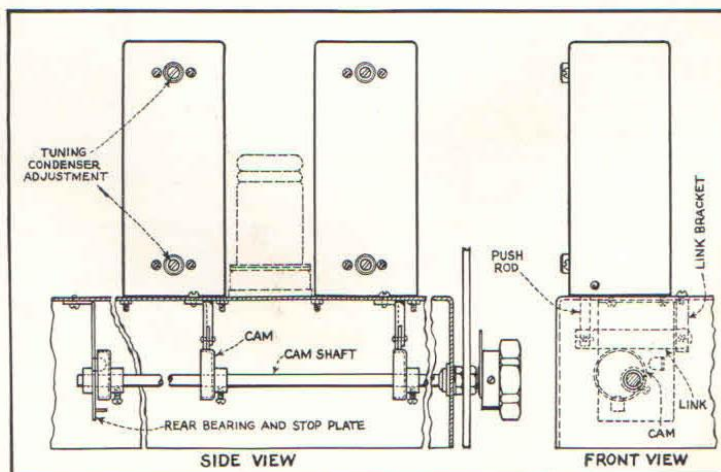

service. The contacts are designed and placed so that the capacity between them is reduced to a negligible amount. This eliminates frequency drift due to change in dielectric constant during temperature rise. The I.F. transformers in the "Super-Pro" are designed particularly for this receiver. Each coil is wound on an Isolantite form and the coupling between them is mechanically variable to provide control of selectivity. Air dielectric trimmers are employed for maximum stability. Each grid coil in the I.F. unit is tapped near the low potential end so that changes in tubes will not affect the alignment of the receiver. This method also permits the use of a large number of stages operating at relatively low gain in order to obtain a maximum degree of selectivity without instability that might exist with a small number of stages operating at maximum gain.

CIRCUIT ARRANGEMENT

TWO-STAGE T.R.F. AMPLIFIER: For maximum sensitivity, high image ratio, and low noise level, the "SP-200" has two stages of tuned radio frequency amplification ahead of the mixer stage. The antenna input circuit is electrostatically shielded from

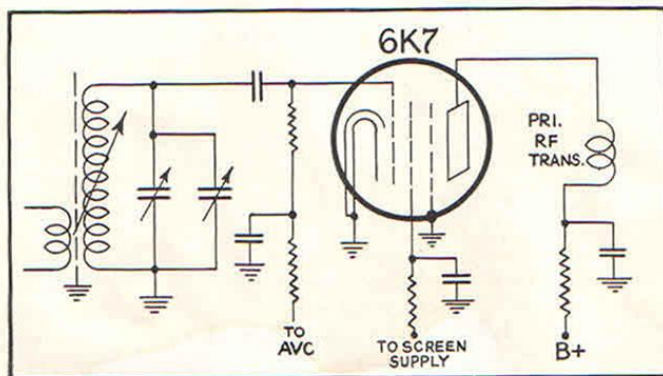

FIG. 2—Circuit diagram of first T.R.F. amplifier showing the electrostatic shield which reduces noise pickup.

the grid circuit of the first tube. This permits the use of low impedance transmission lines between the antenna and the receiver with a minimum of noise pick-up. When lines or lead-ins of the two wire type having an impedance of approximately 100 ohms are employed, no matching transformer is necessary. The input impedance of the receiver is approximately 112 ohms. The two tuned R.F. stages are employed on all bands covered by the receiver. Both inductive and capacitive trimming are employed in all signal frequency circuits.

OSCILLATOR AND MIXER: Two separate tubes are employed in the oscillator and mixer stages to improve stability and prevent pulling. There is a very respectable gain in the mixer stage which tends to minimize any noise that may be generated in the rest of the receiver. In fact, the gain in this stage is so great that the noise contributed by the following stages is negligible.

BAND SPREAD: In order to maintain relatively uniform band spread in the various tuning ranges of the receiver, every gang of the band spread condenser is subdivided into three sections. This allows the use of a proper sized condenser for maximum spread regardless of the position of the wave change switch. There are approximately 85 degrees spread for each of the important amateur bands, and there is also a corresponding spread over the other frequencies outside the amateur band.

CRYSTAL FILTER UNIT: The crystal filter used in the "Super-Pro" is an exclusive HAMMARLUND development and will be found only in HAMMARLUND receivers. This new filter has five ranges of selectivity varying from broad for phone reception, to knife-edge selectivity for single signal code reception. There are three positions for voice reception, and two for C.W. telegraph. The output of the filter is relatively constant over the entire selectivity range and has, therefore, little effect on "S"

FIG. 3—Typical I.F. amplifier circuit with variable selectivity characteristics. Each circuit has isolating resistor and condenser to assure stability.

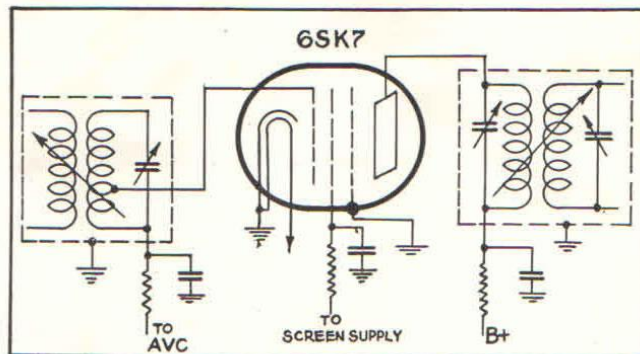

meter readings. Selectivity in the crystal filter circuit is not varied by detuning the load circuit. All circuits remain exactly in tune and selectivity is varied by changing the "Q" of the load circuit. This, together with the balanced phasing condenser, eliminates interlocking of controls and changes in filter gain when the selectivity is varied. Every precaution has been taken to effectively shield all circuits so that there is no feed-back or instability to impair the performance on even the highest frequencies. Stability is further insured by employing isolating resistor networks in every circuit that offers the slightest path for feed-back.

I.F. AMPLIFIER: There are three I.F. amplifier stages in the "SP-200." This elaborate amplifier is required in order to obtain a very high degree of selectivity. Special transformers are employed to hold down the gain per stage in order to maintain a high degree of selectivity and maximum stability. The band width of the I.F. amplifier is controlled by a cam arrangement which varies the coupling in two of the I.F. transformers. The I.F. channel is variable from 16 kc. down to 3 kc. with the crystal filter out of the circuit. The crystal filter, when in the circuit, is variable down to better than 100 cycles. Thus, full range selectivity is available. This wide degree of variable selectivity permits the operator to select the band width providing highest quality reproduction with a minimum of interference. In the "SP-200," the band width can be adjusted to suit operating conditions.

AVC SYSTEM: The automatic volume control system in the "SP-200" is extremely efficient. Both R.F. stages and the first two I.F. stages are automatically controlled by the incoming signal in order to compensate for variation in signal strength due to fading. This system is very fast in operation and will hold a rapidly fading signal to a relatively constant output. Special amplifier and rectifier stages are employed in order to obtain maximum efficiency.

BEAT FREQUENCY OSCILLATOR: The beat frequency oscillator circuit is designed to effectively heterodyne signals of various magnitudes. This oscillator is of the

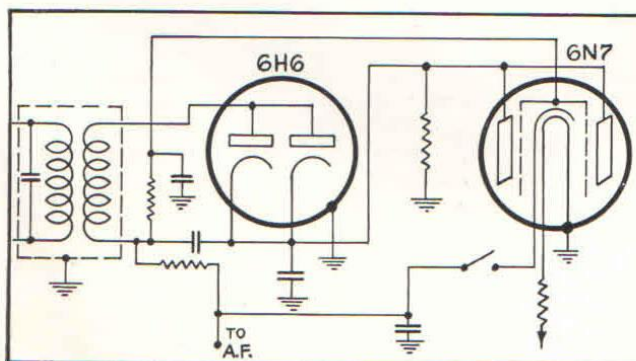

FIG. 4—"Super-Pro" noise limiter designed to reduce automobile ignition interference and other disturbances having similar characteristics.

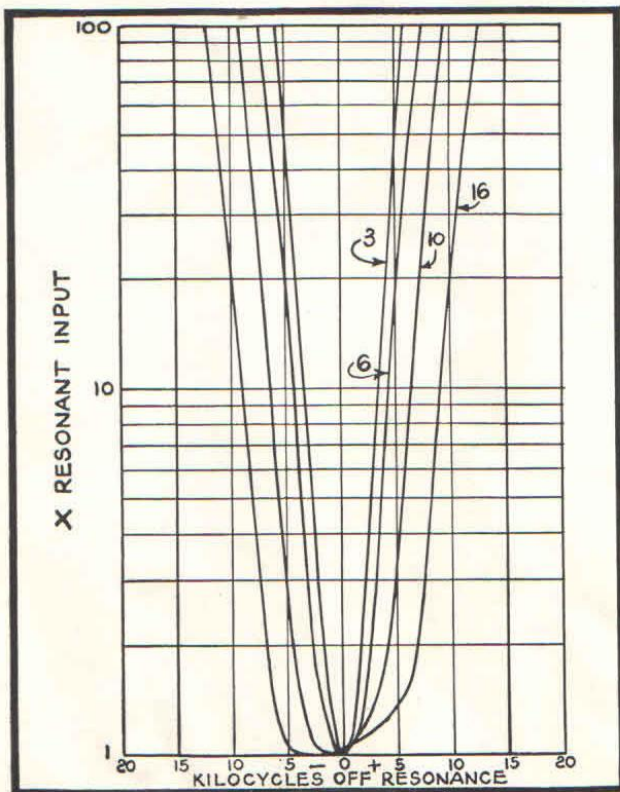

FIG. 5—I.F. curves taken at four positions of the band width control. The actual selectivity of the I.F. amplifier is continuously variable between curves 3 and 16. Particular attention should be paid to the sharp cut-off which greatly reduces back-ground interference.

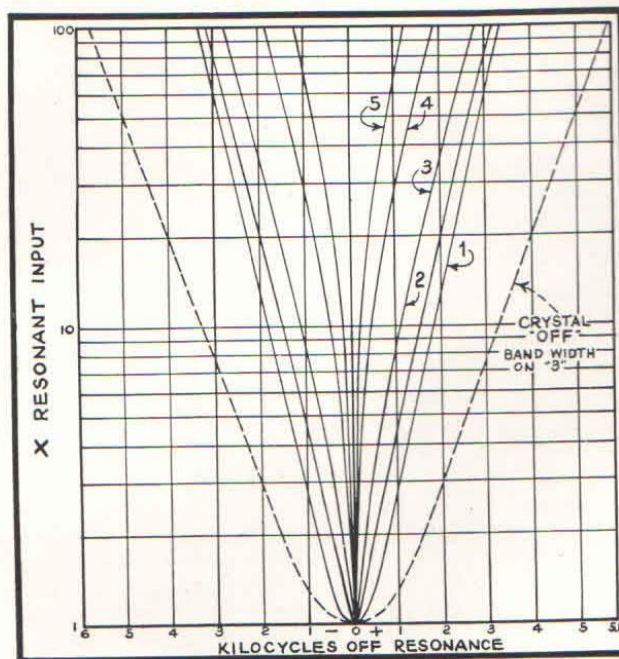

FIG. 6—Variable crystal filter selectivity curves showing five positions of the control switch. Positions 1, 2 and 3 are intended for voice reception. Position 1 is broad enough to permit reception of music. Positions 4 and 5 are for single signal code reception.

electron coupled type and is thoroughly isolated from the rest of the receiver. Careful selection of circuit values has resulted in excellent stability.

SECOND DETECTOR: A 6H6 connected in a half-wave rectifier circuit is employed for the second detector. The proper selection of circuit values in this circuit has resulted in a minimum of distortion. This circuit is more or less conventional and complete technical details are available by referring to the diagram.

NOISE LIMITER: The noise limiter in the "SP-200" is the latest development in audio peak limiting devices. It is designed to work with or without the AVC system and will follow variations in incoming signal strength. It is automatic and needs no adjustment. The limiter is designed to cut off interference of the automobile ignition nature at a point equal to approximately 100% modulation of the carrier of the signal being received. This provides for reception of 100% modulated signals without seriously affecting the quality of the voice or music. It must be remembered that this limiter will only limit interference of very short pulse duration. Such interference, as caused by auto ignition systems and similar disturbances will be reduced to a negligible quantity.

A.F. AMPLIFIER: The audio frequency channel of the series 200 "Super-Pro," is designed for high quality reproduction. The first stage is a 6C5 triode voltage amplifier. The second stage is a single 6F6 triode connected and used as a driver for the output amplifier which is a pair of 6F6's operated in push-pull, class AB. The rated output of this amplifier is approximately 14 watts. The fine quality of the A.F. amplifier in the "Super Pro" is particularly apparent when the band width control is set in the wide position. There is no tone control in this amplifier and none is needed. The A.F. portion of the "Super-Pro" will respond equally well to both low and high frequencies. Attenuation of the higher frequencies is accomplished by narrowing the I.F. band width. In this manner, the band width control serves to control tone.

POWER SUPPLY: The power supply for the "SP-200" is an extra heavy duty unit designed to furnish filament plate and grid bias voltages. The power supply is a separate unit connected to the receiver by a flexible cable. Being a separate unit, the power supply introduces a minimum of hum in the receiver and also reduces the overall temperature rise of the receiver, and thus permits better stability. The high voltage rectifier in the power supply is a 5Z3 connected in a full wave circuit with a two-section filter consisting of 32 mf. capacity and a 15 henry filter choke. The field of the speaker serves as a second filter choke in standard model receivers. In special models, a choke is mounted in the power supply to take the place of the speaker field. Grid bias for the entire receiver is supplied by an 80 rectifier tube operating from a tap on the high voltage secondary. The C-Bias supply also has a multi-section filter consisting of three 8 mf. condensers, and three resistors. The primary of the standard power supply has three taps for operation on 105, 115, and 125 volt power lines. A fuse is also provided to guard against damage in cases of overload.

CALIBRATION: The main tuning dial of the "Super-Pro" is calibrated for all frequencies covered by the receiver. In the process of manufacture, every effort is made to maintain accuracy and, as a result, the accuracy of the calibration is guaranteed to be within $\frac{1}{2}$ of 1% of the highest frequency of the band in use. When using the calibrated dial, it should be remembered that the figures are intended as a tuning guide and not for frequency measuring purposes.

"S" METER: The "S" meter in the "Super-Pro" was designed to provide greatest satisfaction to the operator. It is, in no way, limited by fixed, factory-made adjustments. A variable control on the rear of the chassis allows the operator to set the maximum reading of the meter to conform with his particular system of reporting signal strength in "S" numbers. The meter can be adjusted to read "S-9" on any signal from 10 to 10,000 microvolts. It is adjusted at the factory to indicate "S-9" on a 25 microvolt signal, but as pointed out above, this can readily be changed. Another feature is the centrally located scale. This is much more convenient than a scale that starts at the extreme left of the meter dial, and brings the indicating pointer well out in the clear. Special meter design has also eliminated the possibility of damage due to an extremely strong signal.

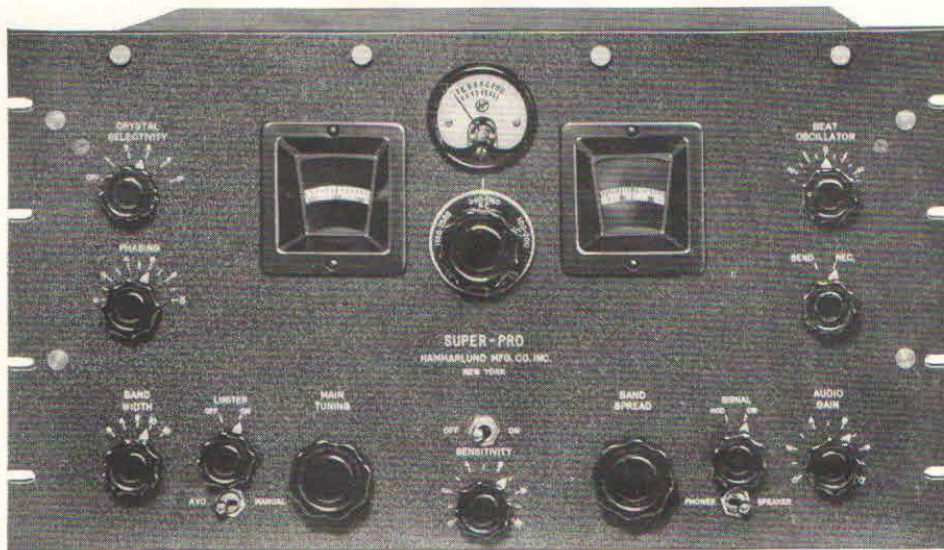

FIG. 8—"SPR-200-X", rack model, designed to fit standard 19" relay rack, complete with dust cover

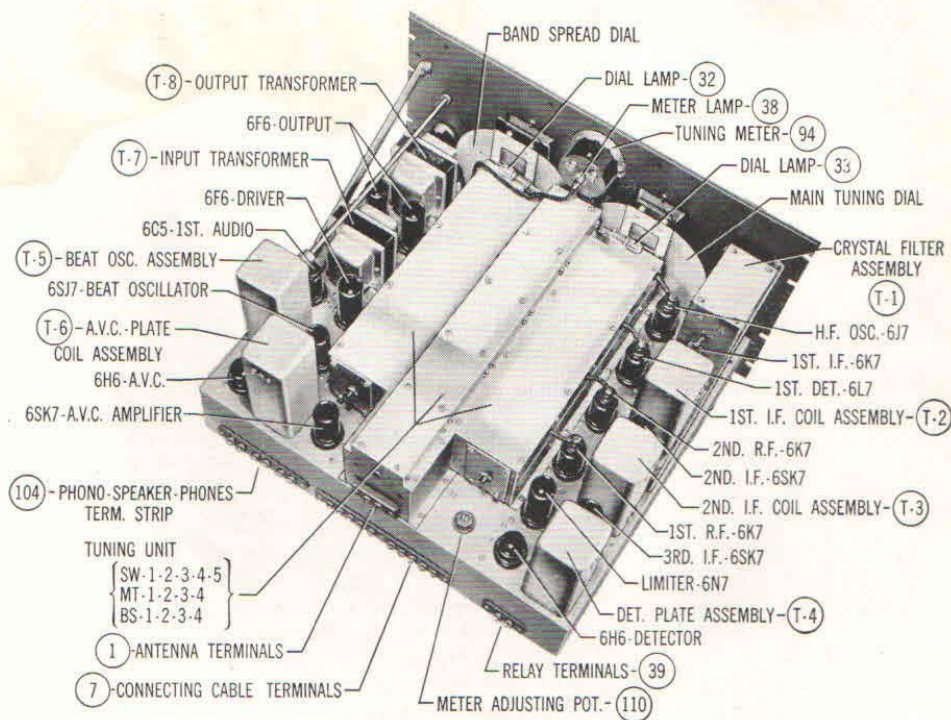

FIG. 7—Top view of "SP-200-X" receiver showing the general layout of parts. All important parts are labeled. Encircled numbers correspond to numbers appearing in the circuit diagram.

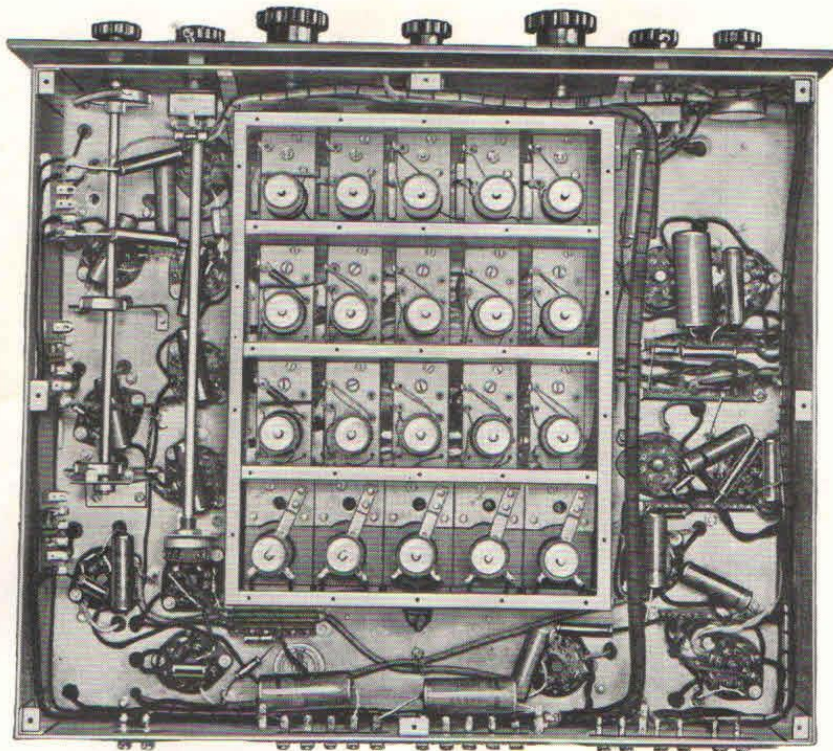

FIG. 9—Bottom view of the "SP-200-X" showing the coil assembly and general lay-out of parts.

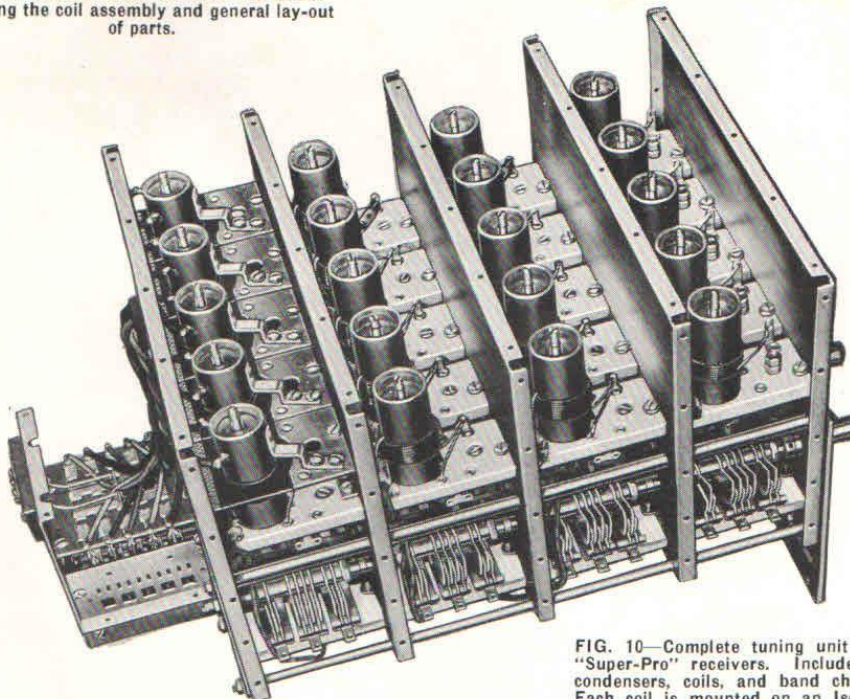

FIG. 10—Complete tuning unit used in all "Super-Pro" receivers. Includes all tuning condensers, coils, and band change switch. Each coil is mounted on an Isolantite base with its associated trimmer condenser.

STANDARD "SUPER-PRO" SERIES 200-X

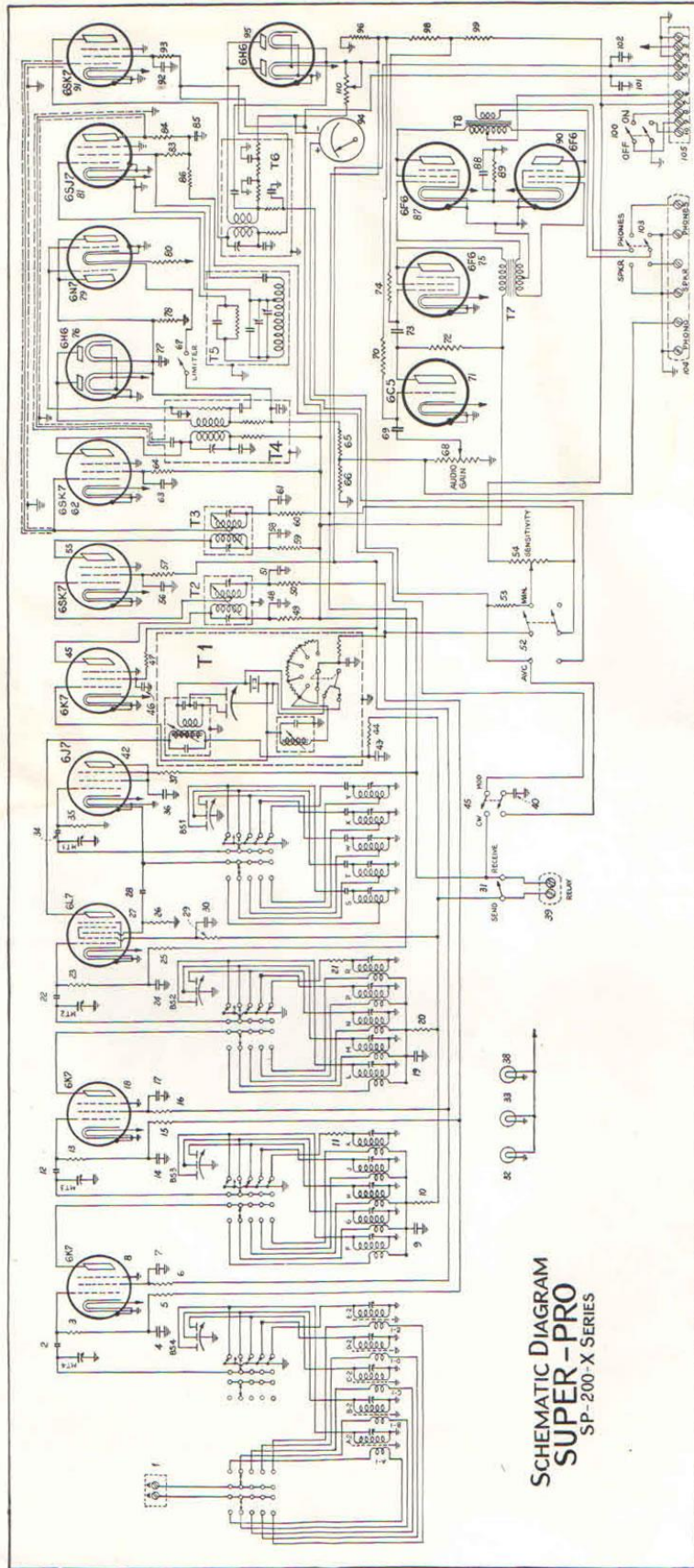

FIG. 11—Wiring diagram of "SP-200-X" receiver

SENSITIVITY

The sensitivity of the "Super-Pro" is exceptional and, in the majority of cases, limited only by noise picked up by the antenna system. Internal receiver noise has been held down to an extremely low value so that the limiting factors in the receiver itself are the noises originating in the first tube and its associated tuned circuit. The gain in the R.F. amplifier is adjusted so as to reduce the effective noise originating in the following tubes and tuned circuits. The result of this proper circuit design is a very favorable signal-to-noise ratio on even very weak signals. Since sensitivity depends, to a great extent, upon overall noise level, the variable selectivity characteristics of the "Super-Pro" becomes doubly important, for, by narrowing the band width, noise can be reduced and thus better sensitivity is available.

PERFORMANCE

The "Super-Pro" is available to cover several frequency ranges. Such information as is given in this book will pertain to all models. The two standard models have the following tuning ranges:

SP-200	SP-200-S
540 - 1160 kc.	1250 - 2500 kc.
1160 - 2500 kc.	2.5 - 5 mc.
2.5 - 5 mc.	5 - 10 mc.
5 - 10 mc.	10 - 20 mc.
10 - 20 mc.	20 - 40 mc.

Other models are available to cover low frequencies in the neighborhood of 150 to 400 kc. as well as certain higher frequencies. In the two standard models, there is a convenient overlap of bands. The main tuning dial is calibrated in megacycles for the three high frequency bands, and in kilocycles for the two low frequency bands. Every effort is made to maintain a high degree of accuracy in calibrating the receiver and it is guaranteed to be at least $\frac{1}{2}$ of 1% of the highest frequency of the band in use.

The sensitivity of the new "Super-Pro" is truly remarkable. By careful circuit design, the overall set noise has been held down to a minimum, thus making it possible to receive extremely weak signals with favorable signal-to-noise ratio. The variable selectivity feature of the "Super-Pro" permits the operator to make full use of the extreme sensitivity even under most severe conditions of interference. Selectivity can be adjusted to cut down interference within very close limits. The advantages of variable selectivity are tremendous when one considers that conditions of interference are not always the same. Under certain conditions, it may be possible to use quite a wide band width and thus enjoy improved tone, as well as easier tuning. Under other conditions, where interference is quite bad, the band width can be narrowed just enough to eliminate interference and in that case, the best possible fidelity that can be obtained without too much interference, is available. In a case where there is practically no interference from other stations, the band width can be adjusted to its widest point and high fidelity reception can be enjoyed.

AVC action in the "Super-Pro" is very efficient. Actual measurements on a sample receiver prove that a very great change in input is required to produce a 2 to 1 change in output. This means that rapidly fading signals can be held to a relatively constant output.

Images (two-spot tuning) on the "Super-Pro" have been eliminated, except in extremely rare cases. The average image ratio will be found to be in the neighborhood of 175,000 to 1 at 1 mc.; 65,000 to 1 at 2 mc.; 34,000 to 1 at 3.5 mc.; 10,000 to 1 at 7 mc.; 1,900 to 1 at 14 mc.; and 150 to 1 at 28 mc.

The audio frequency amplifier in the "Super-Pro" has a rated output of approximately 14 watts. It is capable of excellent quality reproduction. It will be found that the available output power is greatly in excess of that required when the receiver

is used for communication purposes. Greatest intelligibility will be obtained on weak signals when the audio gain is kept down, not because of any amplifier limitation, but because the overall noise level will be too great a shock to the ear and make it difficult to follow the desired signal.

OPERATION

Although the "Super-Pro" is a highly technical piece of apparatus, with quite a large number of controls, it is relatively easy to operate. There are 15 controls on the panel. However, they are not all used at the same time. The number of controls necessary for operation will depend on the type of service for which the receiver is being used. The major controls are the band switch, main tuning, band spread, and audio gain. The remaining controls are brought into play as conditions demand their use. Assuming that the speaker, power supply and antenna have been connected according to instructions, the various controls should be set in the following positions: crystal selectivity, off; "phasing" on zero; "band width" on 6; "limiter," off; switch under the limiter control in "AVC" position; "sensitivity," maximum (10); band spread dial on 100; "signal" switch, on "modulation"; the toggle switch just beneath, should be set on "Speaker"; "audio gain" on 6; send-receive switch on "Rec."; beat oscillator on zero. Then, turn the main switch in the center of the panel marked "On-and-Off" to the on position. This puts the entire receiver in operation. The band switch should be adjusted to either the broadcast band or the next highest frequency band. This should permit reception of local stations and allow the operator to familiarize himself with various adjustments. The band width control should be adjusted to provide the most pleasing tone when there is no serious interference. Otherwise, it should be adjusted to the point providing best tone quality with a minimum of interference. The beat oscillator is turned on when the "signal" switch is in the "CW" position. The beat oscillator control varies the pitch of the heterodyne. This feature is used for code reception and for locating weak signals. The "limiter" control turns the noise limiter on and off. The noise limiter is most valuable on the shorter waves where automobile ignition interference is more serious. So far, we have considered the receiver adjustments necessary for phone reception. For code reception, the "AVC-Man." control should be set in the "Man." position and the sensitivity control turned down to provide proper sensitivity. On strong signals, this control should not be turned all the way on because there will be a tendency to overload the receiver. Volume is controlled with the "audio gain" control and not with the "sensitivity" control. The crystal filter is very effective and easy to operate because of its excellent stability. The first three positions are generally used for phone reception and will serve for code reception where interference is not severe. The last two positions are for code reception exclusively. When the crystal selectivity control is adjusted for optimum selectivity, the phasing control should be used to reject heterodyne interference or "whistle." The receiver can be temporarily silenced by turning the "Send-Receive" switch in the "Send" position. This allows the receiver to be ready for instant service and is more commonly called the "stand by switch" when the receiver is used for communication purposes. All tuning can be done with the main tuning control. In this case, the band spread dial is left at 100. The band spread dial operates so as to spread out a narrow band of frequencies in the neighborhood of the frequency at which the main dial is set. The band spread dial works continuously throughout the entire range of the receiver except on the lowest frequency bands. In this manner, many short wave broadcast or amateur bands can be spread out over the band spread dial for easy tuning. The wave ranges of the receiver are so arranged that when the band spread and main dial are set for 80 meter amateur band reception, the 40-meter band as well as the other amateur bands will appear on the band spread dial merely by turning the wave change switch. This is a great convenience and eliminates the necessity for searching each time for the amateur band which is to be covered by the band spread dial. For ear-phone operation, ear-phones are plugged into the terminal strip so marked on the rear of the chassis, and a switch on the front panel changes the receiver from ear-phone to loud speaker operation.

The next feature for consideration is the "S" Meter. This is used to judge relative signal levels and also as a tuning indicator. Maximum reading of the meter always indicates that the receiver is in exact tune with the station. The meter is calibrated in "S" units from 1 to 9, and the relative reading on any particular signal can be changed by re-setting the meter control adjustment which is located toward the rear of the chassis. The chassis drawing shows the position of this adjustment. A suggested method of adjusting the meter would be to tune in a signal of moderate strength. If you are accustomed to calling this signal, "S-8" or "S-9," then adjust the meter control so that it indicates that value. This adjustable meter arrangement allows the operator to provide reports consistent with his usual system of reporting. No amount of explaining will teach the operator exactly how to control a receiver. Experience is absolutely necessary in order to obtain best results.

ANTENNA REQUIREMENTS

The input of the Series 200 "Super-Pro" is approximately 112 ohms. This means that for best results, the antenna should be coupled to the receiver by means of a low impedance transmission line. The doublet type antenna produces best results. Any well-known low impedance lead-in cable can be used with satisfaction. The use of low impedance lead-ins provides less chance for the lead-in itself to pick up extraneous noises. The low impedance lead-in, together with the electrostatic shield built into the antenna coil of the receiver, reduces noise to a minimum. It must be remembered that every antenna has a period of resonance and works best at that frequency. When erecting a doublet antenna, it is advisable to arrange its physical dimensions so that it will resonate in the band of frequencies where most sensitivity is desired. Care taken in designing and erecting an antenna will pay for itself many times in superior results.

VOLTAGE CHART

TUBE	FUNCTION IN RECEIVER	VOLTS AT SOCKET TERMINAL No.							
		1	2	3	4	5	6	7	8
6K8	1st Radio Freq.	0	0	250	135	...	135	6.3 AC	0
6K8	2nd Radio Freq.	0	0	250	135	...	135	6.3 AC	0
6L7	1st Detector	0	0	250	115	6.3 AC	0
6J7	High Freq. Oscillator	0	0	160	160	160	...	6.3 AC	...
6K7	1st I.F. Amplifier	0	0	250	135	0	...	6.3 AC	0
6SK7	2nd I.F. Amplifier	0	0	0	-43.	0	135	6.3 AC	25.
6SK7	3rd I.F. Amplifier	0	0	0	-2.	0	100	6.3 AC	240
6N7	Noise Limiter	0	0	+ .4	-.2	-.2	+ .4	4.0 AC	-.2
6H6	2nd Detector	0	0	-.2	+ .4	-.2	...	6.3 AC	+ .4
6SK7	AVC Amplifier	0	0	0	-2.	0	110	6.3 AC	240
6H6	AVC	0	0	-3.2	-3.4	-3.2	...	6.3 AC	-3.4
6SJ7	Beat Oscillator	0	0	0	-.1	0	40.	6.3 AC	155.
6C5	1st A.F. Amplifier	0	0	110	-3.3	6.3 AC	0
6F6	A.F. Driver	0	0	240	240	...	-20.	6.3 AC	0
6F6	P.P. A.F. Output	0	0	380	380	0	...	6.3 AC	38.
6F6	P.P. A.F. Output	0	0	380	380	0	...	6.3 AC	38.

Measurements were made on 115 volt AC line, with line voltage adjustment set at 115 volt tap. Set sensitivity and audio gain controls at minimum. A.V.C. Manual Switch should be in manual position. CW-MOD Switch in C.W. position, Limiter Switch in "On" position, and "Send-Receive" switch in receive position. D.C. readings were obtained with voltmeter having a resistance of 1000 ohms per volt. Use chassis as a common terminal. Voltages within $\pm 10\%$ are satisfactory. The 6.3 volt A.C. filament reading is obtained between chassis and terminal No. 2 on strip. Terminal No. 10 on strip is blank except when used for battery operation.

SUPER-PRO MODELS AND PRICES

<i>Code</i>	<i>Type</i>	<i>Tuning Range</i>	<i>Speaker</i>	<i>List Price</i>
SP-210-X	Crystal	15-560 Meters	Jensen 10" Dynamic	\$465.00
SPR-210-X	Crystal Rack	15-560 Meters	Jensen 10" Dynamic	482.50
SP-220-X	Crystal	15-560 Meters	Jensen 12" High Fidelity	490.00
SPR-220-X	Crystal Rack	15-560 Meters	Jensen 12" High Fidelity	507.50
SP-210-SX	Crystal	7½-240 Meters	Jensen 10" Dynamic	465.00
SPR-210-SX	Crystal Rack	7½-240 Meters	Jensen 10" Dynamic	482.50
SP-220-SX	Crystal	7½-240 Meters	Jensen 12" High Fidelity	490.00
SPR-220-SX	Crystal Rack	7½-240 Meters	Jensen 12" High Fidelity	507.50
SP-210-LX	Crystal	*15-2000 Meters	Jensen 10" Dynamic	465.00
SPR-210-LX	Crystal Rack	*15-2000 Meters	Jensen 10" Dynamic	482.50
SP-220-LX	Crystal	*15-2000 Meters	Jensen 12" High Fidelity	490.00
SPR-220-LX	Crystal Rack	*15-2000 Meters	Jensen 12" High Fidelity	507.50
PSC-10	Speaker cabinet finished to match receiver			8.50

Above prices cover 110-115-125 volt, 50 to 60 cycle models with tubes, crystal, and speaker. Receiver and power supply enclosed in wrinkle finished table type metal cabinets. Special models for 50-60 cycles with universal type power supply tapped for 115, 125, 140, 230, and 250 volts, also available at no increase in price. Twenty-five cycle models, \$20.00 additional.

* In this model, the 1000 to 2000 meter band is substituted for the 60 to 120 meter band.

Receiver in cabinet measures 21½" wide, 15¼" deep, and 12¼" high. Power supply in cabinet measures 13" wide, 7½" deep, and 8½" high. Rack models fit standard 19" relay racks. Shipping weight approximately 110 pounds.



HAMMARLUND MFG. CO., INC.

424-438 W. 33rd ST., NEW YORK

Canadian Address: 41 WEST AV., NO., HAMILTON, ONT.